

OTT ecoLog Guidance: Remote communication via mobile networks

As wireless signals travel through the atmosphere, they can be affected by different types of interference, such as physical objects or environmental factors. This interference can weaken the signal strength or prevent reliable remote communication. This technical paper describes the most important interferences and other potential causes of reduced or limited signal strength. It also provides guidance on testing signal strength and selecting appropriate installation components.

Physical Objects:

Any object between the antenna on the OTT ecoLog and the cellular tower will have an influence on the signal strength. The following table compares different types of obstructions and their negative impact on the signal quality (shielding).

Obstruction	Shielding	Examples
Wood	Low	Walls
Plastic	Low	Top caps, cabinets
Concrete	Mid to High	Walls, buildings
Metal	High	Cabinets, manhole covers, top caps
Water	High	Rain, wet leaves, wet snow

Standard wells, top caps or manhole covers are made out of metal, and will likely cause limit remote communication when using in-well ground-water dataloggers with stub antennas, for example the OTT ecoLog.

Environmental Factors:

Some users experience transmission issues during springtime, whereas they have no issues during fall and winter.



This phenomenon stems from the high shielding characteristic of water. Trees with fresh or wet leaves will weaken the signal significantly more, than trees without leaves do.

That means a measuring site in a forest might perform well during fall and winter time, but have issues in springtime. In the same way fog or heavy rain can decrease the signal quality.

Cellular Towers

The first and most obvious factor that has an impact on the signal strength is the distance to the nearest tower. The signal strength decreases roughly in an inverse quadratic relation with respect to the distance ($S \sim 1/d^2$). That means with double distance, the signal becomes four times weaker.

Technical issues such as changes in the antenna position can affect the signal quality. These issues can for example be caused by extreme weather conditions or maintenance work on the cellular tower. That means a measuring station that never had issues with data transmission can suddenly stop transmitting.

Network Usage and Load:

Cellular towers have limited bandwidth for connections, calls, and data transmission. If too many devices are connected to a cell tower it can be impossible for other users to connect. This can happen especially during rush hour or when a cellular tower is located close to an office building.

That means a cellphone can still show five bars for signal quality, but it is not possible to transmit data. In some cases this situation can last several days or it can be even impossible to have GPRS data transmission.

Remedies:

Top Caps for OTT ecoLog 500 & 800

As metal top caps can make remote data transmission impossible, there are two alternatives.

Existing top caps can be equipped with external antennas (see below). Plastic top caps have a very low shielding for radio signals. Additionally, the OTT ecoCap lifts the ecoLog out of the metal well to ensure best possible signal quality.

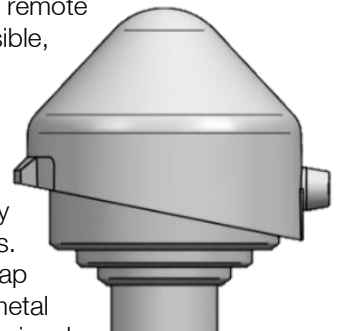

External Antennas

External antennas can help to create a free line of sight (LOS) between the antenna and the cellular tower. Data that might otherwise be lost due to obstructions can be transmitted and received.

OTT Hydromet offers several external antennas for installation on cabinets, poles or buildings.



Only the dedicated external radio antennas specified by OTT may be used for this particular application.

Test Signal Strength

The OTT ecoLog and the OTT netDL offer the possibility to receive and log the Received Signal Strength Indicator (RSSI) value.

For GSM (SMS, data pull) data transmission the RSSI value should be above 10. For GPRS data transmission (FTP, HTTP, SMTP) the value should be above 14.

Logging the RSSI over time can indicate if the signal strength is stable or not.

Another way of testing the signal quality is to use a smartphone. The phone will show either the dBm value or the Arbitrary Strength Unit (ASU) value. For 2G, the ASU value is equal to the RSSI value measured by the OTT dataloggers. The dBm value

Measuring the signal strength with a smartphone

The 3G & 4G networks need to be deactivated to get the value for the 2G (GSM/GPRS) network.

iPhone

For opening the field test app the phone app needs to be opened and the sequence *3001#12345#* needs to be dialed.

Android Smartphone:

Setting > About Phone > Status

should be between -85 and -50 dBm, where -50 dBm is better than -85 dBm.

The signal quality can be unstable. There are several factors that can influence the signal quality and lead to a lower signal quality at a later time. Furthermore, even with a good signal strength the bandwidth can be too low for stable data transmission (cp. "Network Usage and Load").

Network Provider

Not all network providers offer the same signal quality at each location. For this reason, changing the provider may solve issues with signal quality.

The network coverage can be checked on most of the network provider's websites.

OTT Hydromet GmbH

Ludwigstrasse 16
87437 Kempten · Germany
Phone +49 831 5617-0 · Fax -209
info@ott.com
www.ott.com

Customers from USA contact:

OTT Hydromet

5600 Lindbergh Drive
Loveland, CO 80538 · U.S.A.
Phone (970) 669-3050
sales@otthydromet.com
www.ott.com